



WORKS AND SERVICES  
PO BOX 210, MANDURAH WA 6210  
PH: (08) 9550 3777 FAX: (08) 9550 3888  
Email: council@mandurah.wa.gov.au

**Specification for the Construction of  
Standard Type Residential Brick  
Paved Vehicle Crossings**

Residents intending to construct or arrange the construction of a vehicle crossing privately are advised that Council's contribution towards the cost will only be made if all the requirements of this specification are satisfied.

Any claim for Council's contribution must be supported by receipts or invoices for the work and/or materials supplied. A written quote from a contractor is not acceptable for this purpose.

# CITY OF MANDURAH

## Specification for the Construction of Standard Type Residential Brick Paved Vehicle Crossings

This Specification is made pursuant to the provisions of Schedule 9.1.7 of the *Local Government Act 1995*, which requires that vehicle crossings be constructed to Council specifications.

The construction of brick paved crossings shall be executed under the supervision of the Director of Works and Services or his authorised representative, (hereafter referred to as City Engineer), in accordance with this specification and attached Drawing No's STDA01, STDD03, STDD04, STDD05, STDD06, STDD07, STDD08 and STDD10.

The major brick paving manufacturers have identified the requirements of Local Government Authorities for brick paved vehicle crossings and their brochures covering the specifications for construction and laying of the pavers form the basis of this specification.

It is preferable that the internal driveway be constructed prior to the crossing to avoid damage to the crossing.

### **DEFINITION - STANDARD RESIDENTIAL CROSSOVERS**

- a) Under Section 12/2 of Council's Policy Manual a "Standard Crossing" place shall provide a minimum 2.8m wide pavement splayed at the road edge or kerb with a 1.0m x 3.0m wing on each side, that is constructed in accordance with this document.

Council contribution towards the construction of a crossover will only be made if the width of the crossover pavement is no less than 2.8m.

Although the crossover may be wider than 2.8m, Council reimbursement will only be paid up to a maximum width of 3m.

- b) It should be noted that these specifications only apply to roads controlled by Council; roads controlled by Main Roads Western Australia (Fremantle Road, Mandurah Bypass, Old Coast Road, part of Pinjarra Road) must have vehicle crossing places built to their specifications.

### **STRATA TITLED PROPERTIES**

Council subsidy is only available to strata titled properties that have road frontage to a constructed road and individual vehicle crossings. Council subsidy is not available to strata title developments that share a common driveway.

1. **Principal Requirements for Paved Crossovers**

1.1 A clay or concrete paving crossing shall consist of:-

- a) Compacted Subgrade - Compaction of naturally occurring ground.
- b) Compacted Sub-base - A 100mm layer of limestone or crushed rock.
- c) Compacted bedding sand layer of 30mm.
- d) Course of paving bricks.
- e) Firm edge restraint to prevent lateral movement of paving bricks at edges. This prevents other bricks rotating under traffic and losing interlock. The edge restraint must be as shown on Drawing No. STDD08. Where the crossing meets the pavement, the pavement acts as the edge restraint.

1.2 Paving bricks shall be of high quality and comply with the City of Mandurah specification for paving bricks. Clay house bricks will not be approved for use in crossovers.

1.3	Paver Dimensions: Brick Shape	Nominal Sizes	230mm x 115mm 230mm x 150mm 200mm x 200mm
	Square Shape		

1.4	Minimum Paver Thickness	Residential	60mm
-----	-------------------------	-------------	------

1.5	Paving Pattern: Brick Shape	Herringbone	90° or 45°
	Square Shape	Angle from kerblines	45°

1.6	Minimum Width at Property Line		2.8 metres
-----	--------------------------------	--	------------

1.7	Maximum Width (Excluding Wings)	Single Residential	6 metres
		Duplex	7.5 metres
		Multiple Residential and Commercial	10 metres

1.8	Wing Dimension	Splayed on each side at the kerb	1.0m x 3.0m splay at 70° to the kerb
-----	----------------	----------------------------------	--------------------------------------

1.9	Length	From the edge of the road to the property line. Determined by width of the road reserve.	
-----	--------	--	--

1.10	Existing Reticulation Systems	Removal and reinstatement of any reticulation system in the area of the proposed crossover must be carried out by the ratepayer.	
------	-------------------------------	--	--

1.11 Future Path Construction

Where the construction of a new footpath/dual use path is undertaken, Council policy requires the removal of any material other than plain grey concrete from driveways/crossovers and reinstatement with plain grey concrete to ensure uniformity of the path system. The section to be removed is to be the width of the path. The cost of reinstatement will be borne by the City.

2. **Location**

A paved crossing shall:-

- a) **Only be installed where it abuts a kerbed road**, (if the road is not kerbed, an asphalt crossing is required).
- b) Be located to not cause interference to public utility facilities in the verge and to avoid trees.
- c) **Not be positioned within a corner truncation** or closer than 7m from the property line intersection point at corner sites/where no truncation exists on corner lots.
- d) Be constructed at 90<sup>0</sup> to the kerb line.
- e) Be positioned a minimum of one metre from the side boundary or truncation peg.

3. **Levels and Shape**

If the internal driveway has not been constructed, the level of the driveway at the property boundary shall be obtained from the City Engineer giving 48 hours notice. Refer to the attached standards regarding carport and verge levels for various locations (STDD04, STDD05 & STDD06).

Crossovers are not to be higher or lower than the surrounding natural ground level in such a manner that would cause difficulty for pedestrian access. This precludes the use of raised kerbing or raised edging along the edges of crossovers within the first two metres from the kerb back.

3.1 **Unkerbed Roads in Rural/Special Rural Areas, (eg Goegrup, Pleasant Grove, Wannanup etc.)**

All crossovers which go over a swale drain or drainage ditch require a pipe culvert to be installed. The City will supply and deliver at no charge two (2) culvert pipes. The owner of the property may obtain additional pipes at their own cost if required. Request forms for the delivery/collection of culvert pipes are available from the City of Mandurah's Administration Office, 3 Peel Street, Mandurah.

Two 225mm diameter concrete pipes, 2.44 metres long, will be delivered within three (3) working days of being ordered, to the required address.

Please note, the property owner must ensure the pipe culvert is maintained and kept clear of grass and debris at all times.



4. **Public Utility Services and Trees**

Every endeavour should be made to avoid public utility services and trees present in the verge when locating the vehicle crossing.

**Approval must be obtained prior to any relocation of, or alternations to, the existing utilities services or facilities and/or the removal of trees to make way for the crossing. All work and costs shall be at the ratepayer's expense. City of Mandurah drainage manholes will be adjusted by Council at the ratepayer's expense if the existing level is in conflict with the proposed crossover.**

The removal of any trees will need written authorisation from the City's Horticultural Technical Officer.

5. **Path Removal**

Where an existing footpath is in the location of a proposed vehicle crossover:-

- a) If the footpath is precast concrete slabs:  
the contractor shall remove the slabs that conflict with the new crossover location. Once the crossover has been completed any gaps between the crossover and the slab path shall be rectified by cutting slabs to the correct shape and replacing so that the path carries through the crossover and ensures smooth uniformity of path material and enhance safety of the path user. Any leftover slabs shall be removed from site by the contractor at their expense.
- b) If the footpath is in-situ concrete and is less than 100mm thick:  
the contractor shall cut the concrete footpath using an approved concrete saw parallel to the proposed alignment of the crossover. This section of footpath shall be replaced by grey concrete to the specified thickness. A gap of 12mm shall be left between the footpath and the crossover for the provision of an expansion joint (canite strip) to be placed on both sides of the crossover. If a loose fillet of footpath, (less than 0.1m<sup>2</sup>), is left by this process it should be replaced by incorporation into the crossover. All replaced sections of footpath and rubble shall be removed from site by the contractor at their expense.
- c) If the footpath is in-situ concrete and has a thickness of 100mm or more:  
construct the vehicle crossing either side of the footpath. (ie. Paving to butt up to the in-situ concrete).

**NOTE: Confirmation of the thickness should be obtained from the City Engineer.**

6. **Removal of Kerbing**

Where barrier or semi-mountable kerbing is in place at the crossing entrance, the length of kerbing equal to the appropriate entrance width of the crossing and transitions shall be removed in all cases.

Where mountable kerbing is in place at the crossing entrance, the crossing is installed to abut the kerbing. The length of mountable kerbing equal to the appropriate entrance width of the crossing shall be removed where the mountable kerbing is damaged or displaced

In no circumstances shall asphalt or any other filling material be placed in front of the existing kerbing to provide smoother transition between the road pavement and the crossover. If the owner requires a smoother transition between the road and the crossover, the existing mountable kerbing may be replaced by "Layback Kerbing", refer drawing STDA01.

**Where kerbing is to be removed, it shall be cut clean and removed carefully so as not to disturb the surface of the roadway.**

7. **Crossing Entrance**

Where kerbing has been removed to permit the construction of a crossover refer to Drawing No's STDA01 and STDD08 for replacement kerb types and details.

Ensure a lip of 25-30mm shall be created between the road surface and the top of the front edge of the crossing entrance to allow for the future resurfacing of the road.

Any damage caused to the edge of the road surface shall **not** be corrected with concrete. The City Engineer shall be advised of the damage on completion of the crossing and arrangements will be made for its repair.

8. **Wide Crossings**

Where two residential crossings abut one to the other, they may be combined, subject to the combined width not exceeding 10 metres.

Where the combined width would exceed 10 metres, the two crossings shall be separated by a pedestrian refuge of 1 metre minimum width.

9. **Construction (See Drawing No's STDD08 and STDD10)**

9.1 **Excavation**

The excavation shall be to the levels and grades as given for the site. All excavation shall be executed cleanly to provide for a sound base free of depressions, soft spots or any deleterious materials.

The crossing bed shall be watered and compacted to give compaction of 95% of maximum modified dry density. Adequate compaction is essential, particularly in the wing areas.

9.2 **Sub-Base**

The sub-base materials shall be loosely spread in one layer to the required level. If necessary, water shall be added before compaction to reach the correct moisture content.

The sub-base shall be compacted using overlapping passes of the vibrating plate compactor. It shall be closely trimmed to the required levels.



### 9.3 Sand Bedding Layer

This material shall consist of a well graded concreting sand passing a 4.72mm sieve. Since the appearance of the paving surface will be important, the sand should be free of soluble salts or other contaminants which could cause efflorescence. At the time of placing, the sand shall have a uniform moisture content.

The sand shall be spread and screeded in a loose condition, to a thickness such that the recommended thickness of 30mm is achieved after compaction. If accidental precompaction occurs by foot traffic, rain or even where the sand is left uncovered overnight the sand layer must be brought back to its loose condition before further paving proceeds.

### 9.4 Laying Paving Bricks

Paving normally commences from the lowest level edge restraint. Where the crossing and driveway are to be constructed at the same time, the starting point may be either at the kerb line or the end of the driveway, whichever is the lowest.

Paving bricks should be placed with 2 to 4mm gaps between adjacent bricks, maintaining correct joint alignment but without precompaction of the sand bedding layer. It is important that the joint width between paving bricks be maintained. If paving bricks are placed directly against each other it may be difficult to maintain an even laying pattern and to compact the sand bedding without damage to the bricks. **Full bricks must be used for the header bricks** (first row of bricks) on the three edge rows of the crossover. Any gaps at the pavement edge adjacent to edge restraints can be neatly filled by cutting paving bricks to size using a brick saw. To fill small gaps less than a quarter block in size, mortar should be used.

### 9.5 Compaction and Joint Filling

After laying, the bricks should be immediately compacted and brought to level by not less than three passes of the vibrating plate compactor. The plate should have sufficient area to simultaneously cover 12 paving bricks. As soon as possible after compaction, sand for joint filling should be broomed over the pavement and into the joints. Excess sand should be removed as soon as the joints are filled.

Ideally the sand used for joint filling should be finer than the sand used for the bedding layer with a nominal maximum particle size of 2.36mm. Sand used for joint filling should be free of soluble salts or other contaminants which could cause efflorescence. The addition of a small amount of silty material to the joint filling sand can be of considerable benefit in reducing water penetration in the early life of the crossing or driveway.

## 10. Material Quality

All materials used in the construction of vehicle crossings shall be in accordance with the standard specification of Council and any material used which is inferior to those specified or as directed by the City Engineer shall be liable to rejection and replacement without payment or compensation being made to the contractor for the supply, delivery, laying, placing, finishing, removal or disposal of anything so rejected as directed by the City Engineer.

11. **Protection of Works**

Protection of works and the public shall be provided by the contractor who shall supply and keep supplied as directed all necessary signs, barricades, road warning lamps, temporary bridges or any other thing necessary or as may be directed by the City Engineer and failure to provide or keep provided shall render the contractor liable under Schedule 9.1.8 of the *Local Government Act 1995*.

Any damage which may occur to any Council facilities or private property during the course of the works or which may subsequently become evident from the operations thereof shall be the sole responsibility of the contractor who shall be held responsible for the repair, replacement, legal claim liability or any other thing which may arise from the carrying out of any such works.

12. **Canite Material**

Approved canite-type material shall be such that when it is subject to compression in hot weather, no bitumen is extruded. The following materials are approved and the use of any other material requires the approval of the City Engineer:-

NON PORITE                      Bitumen impregnated canite by the cold solvent process.

FOSROC EXPANDITE

MELJOINT

13. **Contribution**

If it is a first vehicle crossing constructed to the premises, Council may contribute towards the cost. Application for a subsidy payment must be made on the prescribed form within 6 months of the date it was constructed and is to be accompanied by proof of payment, (invoice or delivery docket).

Council will pay a subsidy of \$21.00 per square metre toward the cost of one Standard Residential crossover and \$42.50 per lineal metre toward the cost of one Standard Industrial crossover per property upon application, provided such application meets the above specifications.

Application forms are available from the City of Mandurah, Administration Office, 3 Peel Street, Mandurah.

14. **Second Crossover**

Upon application, Council may approve a second crossover to any property, subject to the compliance of the above specification, however, no subsidy is applicable.



## CARPORT LEVELS AND DRIVEWAY GRADIENTS

Due to difficulties experienced with the setting of driveway gradients, a comprehensive guide to these gradients has been laid out.

The relevant points are:-

1. The changes of grade on the attached plan(s) are NOT to be exceeded, as these are the maximum permissible in design calculations.
2. Carport levels are set according to the table, in the absence of a carport, the finished floor level of the residence is set. If this does not appear satisfactory to the owner, then they should be consulted.
3. Under NO circumstances should the verge be excavated. This is because of the location of services along the boundary line, specifically telecommunication cables, which are generally only buried 300mm below the surface.
4. An appeal against the above condition may be lodged with the Works and Services Department, **PRIOR** to installation of the crossover.
5. If the verge is not constructed at 2% to the boundary, contact the Works and Services Department for the plan that shows the grades available for such a situation. This must be done in conjunction with a site meeting to ascertain the exact location of services, damage caused during construction etc. This situation is rare and must be dealt with carefully.



ANGLES BETWEEN FRONT BOUNDARIES  
BISECTED AND PROJECTED TO  
KERBLINE

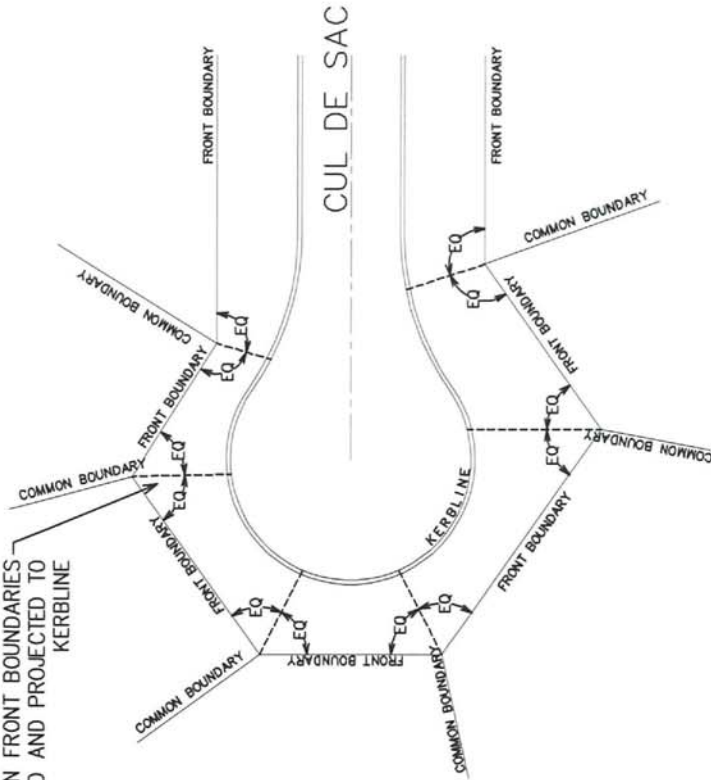

**METHOD 1 – BISECTING ANGLE**

**NOTES:**

1. METHOD 1 TO BE USED IN CONSULTATION WITH THE ADJOINING NEIGHBOURS.
2. METHOD 2 TO BE USED WHERE METHOD 1 WILL NOT ACCOMMODATE CROSSOVERS AND IS TO BE USED ONLY IN CONSULTATION WITH THE ADJOINING NEIGHBOURS AND COUNCIL.

LINE EXTENDED 90° FROM  
KERBLINE TO COMMON  
BOUNDARY

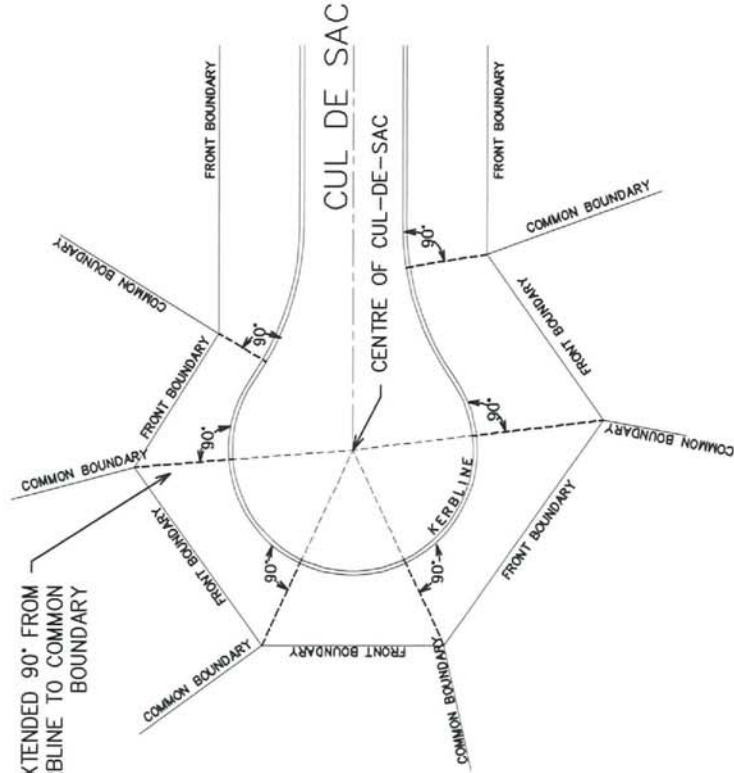

**METHOD 2 – PERPENDICULAR (90°)  
FROM KERBLINE**

REV No.	DATE	DESCRIPTION	BY	CHK'D	APPR	DATE	Designed	Approved
							Drawn	Position
							Draft Check	Date
A	04/08	UPDATED FROM D03	BA				Eng. Check	

<p>TITLE: <b>VERGE ALLOCATION AT CUL-DE-SAC HEADS</b></p>		<p>FILE: \\STANDARD DRAWINGS\COM STANDARD DRAWINGS\0 - CROSSOVERS\STD CROSSING</p>	<p>DWG No: <b>A4 STD CR03/A</b></p>
		<p>SCALE: <b>N.T.S</b></p>	



	3	4	5	6	7	8	9	10	11	12	13
3.2	.51	.53	.55	.57	.59	.61	.63	.65	.67	.69	.71
3.6	.56	.58	.60	.62	.64	.66	.68	.70	.72	.74	.76
4.0	.62	.64	.66	.68	.70	.72	.74	.76	.78	.80	.82
4.4	.68	.70	.72	.74	.76	.78	.80	.82	.84	.86	.88
4.8	.73	.75	.77	.79	.81	.83	.85	.87	.89	.91	.93
5.2	.79	.81	.83	.85	.87	.89	.91	.93	.95	.97	.99
5.6	.84	.86	.88	.90	.92	.94	.96	.98	1.00	1.02	1.04
6.0	.90	.92	.94	.96	.98	1.00	1.02	1.04	1.06	1.08	1.10
6.4	1.00	1.02	1.04	1.06	1.08	1.10	1.12	1.14	1.16	1.18	1.20
6.8	1.10	1.12	1.14	1.16	1.18	1.20	1.22	1.24	1.26	1.28	1.30
7.2	1.20	1.22	1.24	1.26	1.28	1.30	1.32	1.34	1.36	1.38	1.40
7.6	1.30	1.32	1.34	1.36	1.38	1.40	1.42	1.44	1.46	1.48	1.50
8.0	1.40	1.42	1.44	1.46	1.48	1.50	1.52	1.54	1.56	1.58	1.60
8.4	1.50	1.52	1.54	1.56	1.58	1.60	1.62	1.64	1.66	1.68	1.70
8.8	1.60	1.62	1.64	1.66	1.68	1.70	1.72	1.74	1.76	1.78	1.80
9.2	1.70	1.72	1.74	1.76	1.78	1.80	1.82	1.84	1.86	1.88	1.90
9.6	1.80	1.82	1.84	1.86	1.88	1.90	1.92	1.94	1.96	1.98	2.00
10.0	1.90	1.92	1.94	1.96	1.98	2.00	2.02	2.04	2.06	2.08	2.10
10.4	2.00	2.02	2.04	2.06	2.08	2.10	2.12	2.14	2.16	2.18	2.20
10.8	2.10	2.12	2.14	2.16	2.18	2.20	2.22	2.24	2.26	2.28	2.30
11.2	2.20	2.22	2.24	2.26	2.28	2.30	2.32	2.34	2.36	2.38	2.40
11.6	2.30	2.32	2.34	2.36	2.38	2.40	2.42	2.44	2.46	2.48	2.50
12.0	2.40	2.42	2.44	2.46	2.48	2.50	2.52	2.54	2.56	2.58	2.60
12.4	2.50	2.52	2.54	2.56	2.58	2.60	2.62	2.64	2.66	2.68	2.70
12.8	2.60	2.62	2.64	2.66	2.68	2.70	2.72	2.74	2.76	2.78	2.80
13.2	2.70	2.72	2.74	2.76	2.78	2.80	2.82	2.84	2.86	2.88	2.90
13.6	2.80	2.82	2.84	2.86	2.88	2.90	2.92	2.94	2.96	2.98	3.00

VERGE LENGTH

S  
E  
T  
B  
A  
C  
K  
  
F  
R  
O  
M  
  
B  
O  
U  
N  
D  
A  
R  
Y

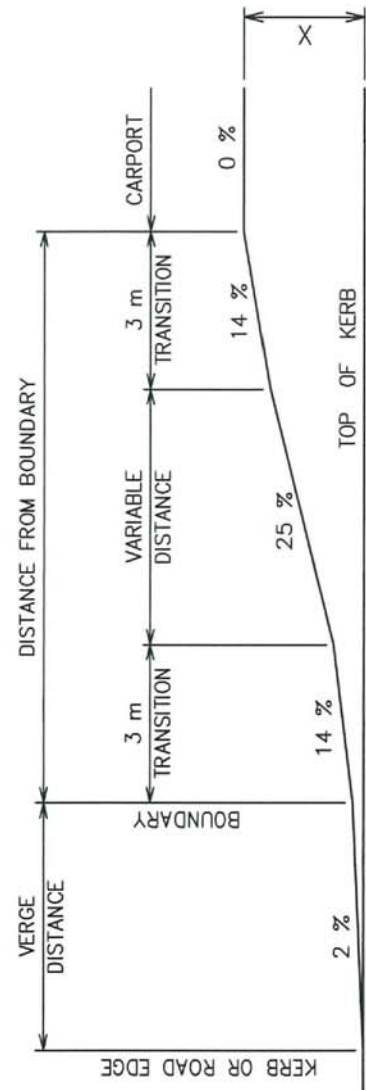

**NOTES:**

- FIGURES INSIDE THE CHART ARE THE MAXIMUM HEIGHT DIFFERENCE (X) BETWEEN THE TOP OF KERB AND CARPORT FLOOR LEVEL.
- DIMENSIONS AND MEASUREMENTS IN METRES.

	<b>TITLE: MAXIMUM CARPORT LEVEL AND DRIVEWAY GRADES FOR VERGES AT 2% GRADIENT</b>			SCALE: <b>N.T.S</b>	DWG No: <b>A4 STD CR04/A</b>
REV No. DATE	DESCRIPTION	BY CHK'D APPR DATE	Designed Drawn Draft Check Eng. Check	Approved Position Date	
A 04/08	UPDATED FROM D04	BA	BA BA BA BA	BA BA BA BA	07/08    

	3	4	5	6	7	8	9	10	11	12	13
3.2	.52	.62	.72	.82	.92	1.02	1.12	1.22	1.32	1.42	1.52
3.6	.61	.71	.81	.91	1.01	1.11	1.21	1.31	1.41	1.51	1.61
4.0	.70	.80	.90	1.00	1.10	1.20	1.30	1.40	1.50	1.60	1.70
4.4	.79	.89	.99	1.09	1.19	1.29	1.39	1.49	1.59	1.69	1.79
4.8	.88	.98	1.08	1.18	1.28	1.38	1.48	1.58	1.68	1.78	1.88
5.2	.96	1.06	1.16	1.26	1.36	1.46	1.56	1.66	1.76	1.86	1.96
5.6	1.05	1.15	1.25	1.35	1.45	1.55	1.65	1.75	1.85	1.95	2.05
6.0	1.14	1.24	1.34	1.44	1.54	1.64	1.74	1.84	1.94	2.04	2.14
6.4	1.24	1.34	1.44	1.54	1.64	1.74	1.84	1.94	2.04	2.14	2.24
6.8	1.34	1.44	1.54	1.64	1.74	1.84	1.94	2.04	2.14	2.24	2.34
7.2	1.44	1.54	1.64	1.74	1.84	1.94	2.04	2.14	2.24	2.34	2.44
7.6	1.54	1.64	1.74	1.84	1.94	2.04	2.14	2.24	2.34	2.44	2.54
8.0	1.64	1.74	1.84	1.94	2.04	2.14	2.24	2.34	2.44	2.54	2.64
8.4	1.74	1.84	1.94	2.04	2.14	2.24	2.34	2.44	2.54	2.64	2.74
8.8	1.84	1.94	2.04	2.14	2.24	2.34	2.44	2.54	2.64	2.74	2.84
9.2	1.94	2.04	2.14	2.24	2.34	2.44	2.54	2.64	2.74	2.84	2.94
9.6	2.04	2.14	2.24	2.34	2.44	2.54	2.64	2.74	2.84	2.94	3.04
10.0	2.14	2.24	2.34	2.44	2.54	2.64	2.74	2.84	2.94	3.04	3.14
10.4	2.24	2.34	2.44	2.54	2.64	2.74	2.84	2.94	3.04	3.14	3.24
10.8	2.34	2.44	2.54	2.64	2.74	2.84	2.94	3.04	3.14	3.24	3.34
11.2	2.44	2.54	2.64	2.74	2.84	2.94	3.04	3.14	3.24	3.34	3.44
11.6	2.54	2.64	2.74	2.84	2.94	3.04	3.14	3.24	3.34	3.44	3.54
12.0	2.64	2.74	2.84	2.94	3.04	3.14	3.24	3.34	3.44	3.54	3.64
12.4	2.74	2.84	2.94	3.04	3.14	3.24	3.34	3.44	3.54	3.64	3.74
12.8	2.84	2.94	3.04	3.14	3.24	3.34	3.44	3.54	3.64	3.74	3.84
13.2	2.94	3.04	3.14	3.24	3.34	3.44	3.54	3.64	3.74	3.84	3.94
13.6	3.04	3.14	3.24	3.34	3.44	3.54	3.64	3.74	3.84	3.94	4.04

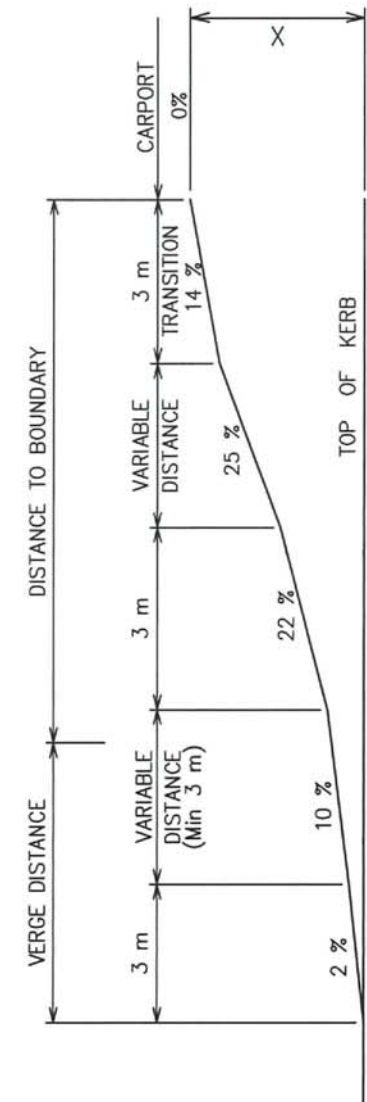

**NOTES:**

- FIGURES INSIDE THE CHART ARE THE MAXIMUM HEIGHT DIFFERENCE (X) BETWEEN THE TOP OF KERB AND CARPORT FLOOR LEVEL
- DIMENSIONS AND MEASUREMENTS ARE IN METRES.

REV No. DATE	DESCRIPTION	BY	CHK'D	APPR	DATE	Designed	Approved
						Drawn	Position
						Draft Check	Date
						Eng. Check	
A	04/08	UPDATED FROM D05	BA				

**TITLE: MAXIMUM CARPORT LEVEL AND DRIVEWAY GRADES FOR VERGES EXCEEDING 2% GRADIENT**

FILE: J:\STANDARD DRAWINGS\COM STANDARD DRAWINGS\ CROSSOVERS\ STD CROSS.DWG SCALE: AS SHOWN DWG No: A4 STD CR05/A

	VERGE LENGTH												
	3	4	5	6	7	8	9	10	11	12	13		
S	3.2	.26	.24	.22	.20	.18	.16	.14	.12	.10	.08	.06	
E	3.6	.30	.28	.26	.24	.22	.20	.18	.16	.14	.12	.10	
T	4.0	.34	.32	.30	.28	.26	.24	.22	.20	.18	.16	.14	
B	4.4	.38	.36	.34	.32	.30	.28	.26	.24	.22	.20	.18	
A	4.8	.42	.40	.38	.36	.34	.32	.30	.28	.26	.24	.22	
K	5.2	.46	.44	.42	.40	.38	.36	.34	.32	.30	.28	.26	
C	5.6	.50	.48	.46	.44	.42	.40	.38	.36	.34	.32	.30	
C	6.0	.54	.52	.50	.48	.46	.44	.42	.40	.38	.36	.34	
K	6.4	.63	.61	.59	.57	.55	.53	.51	.49	.47	.45	.43	
F	6.8	.72	.70	.68	.66	.64	.62	.60	.58	.56	.54	.52	
R	7.2	.80	.78	.76	.74	.72	.70	.68	.66	.64	.62	.60	
O	7.6	.89	.87	.85	.83	.81	.79	.77	.75	.73	.71	.69	
M	8.0	.98	.96	.94	.92	.90	.88	.86	.84	.82	.80	.78	
M	8.4	1.07	1.05	1.03	1.01	.99	.97	.95	.93	.91	.89	.87	
B	8.8	1.16	1.14	1.12	1.10	1.08	1.06	1.04	1.02	1.00	.98	.96	
O	9.2	1.24	1.22	1.20	1.18	1.16	1.14	1.12	1.10	1.08	1.06	1.04	
U	9.6	1.33	1.31	1.29	1.27	1.25	1.23	1.21	1.19	1.17	1.15	1.13	
N	10.0	1.42	1.40	1.38	1.36	1.34	1.32	1.30	1.28	1.26	1.24	1.22	
D	10.4	1.51	1.49	1.47	1.45	1.43	1.41	1.39	1.37	1.35	1.33	1.31	
A	10.8	1.60	1.58	1.56	1.54	1.52	1.50	1.48	1.46	1.44	1.42	1.40	
R	11.2	1.68	1.66	1.64	1.62	1.60	1.58	1.56	1.54	1.52	1.50	1.48	
A	11.6	1.77	1.75	1.73	1.71	1.69	1.67	1.65	1.63	1.61	1.59	1.57	
R	12.0	1.86	1.84	1.82	1.80	1.78	1.76	1.74	1.72	1.70	1.68	1.66	
Y	12.4	1.95	1.93	1.91	1.89	1.87	1.85	1.83	1.81	1.79	1.77	1.75	
	12.8	2.04	2.02	2.00	1.98	1.96	1.94	1.92	1.90	1.88	1.86	1.84	
	13.2	2.12	2.10	2.08	2.06	2.04	2.02	2.00	1.98	1.96	1.94	1.92	
	13.6	2.21	2.19	2.17	2.15	2.13	2.11	2.09	2.07	2.05	2.03	2.01	

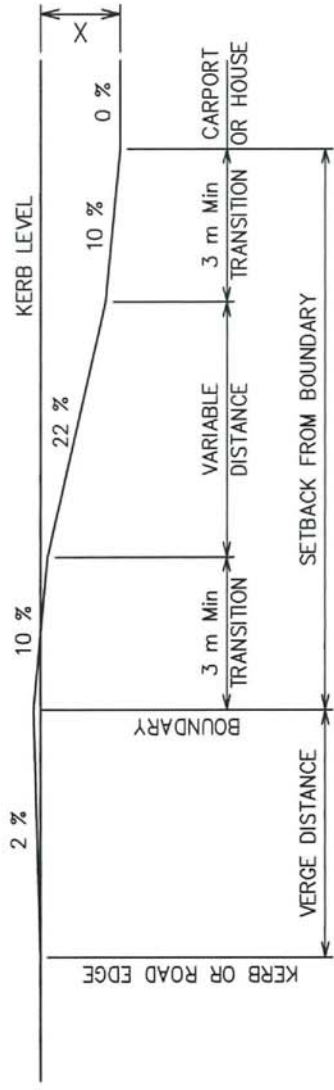

**NOTES:**

- FIGURES INSIDE THE CHART ARE THE MAXIMUM HEIGHT DIFFERENCE (X) BETWEEN THE TOP OF KERB AND CARPORT FLOOR LEVEL
- DIMENSIONS AND MEASUREMENTS ARE IN METRES.

<b>REV No.</b>	<b>DATE</b>	<b>DESCRIPTION</b>	<b>BY</b>	<b>CHK'D</b>	<b>APPR/DATE</b>	
A	04/08	UPDATED FROM D06	BA			
			<b>Designed</b>			
			<b>Drawn</b>	BA	07/08	<b>Approved</b>
			<b>Draft Check</b>			
			<b>Eng. Check</b>			
			<b>Position</b>			
			<b>Date</b>			
<b>TITLE: MINIMUM CARPORT LEVEL AND DRIVEWAY GRADES FOR VERGES AT 2% GRADIENT</b>						
<small>FILE: \\A:\STANDARD DRAWINGS\COM\STANDARD DRAWINGS\0 CROSSINGS\STD_CROSS.DWG</small>				<b>SCALE:</b> <b>NTS</b>	<b>DWG No:</b> <b>A 4 STD CR06/A</b>	



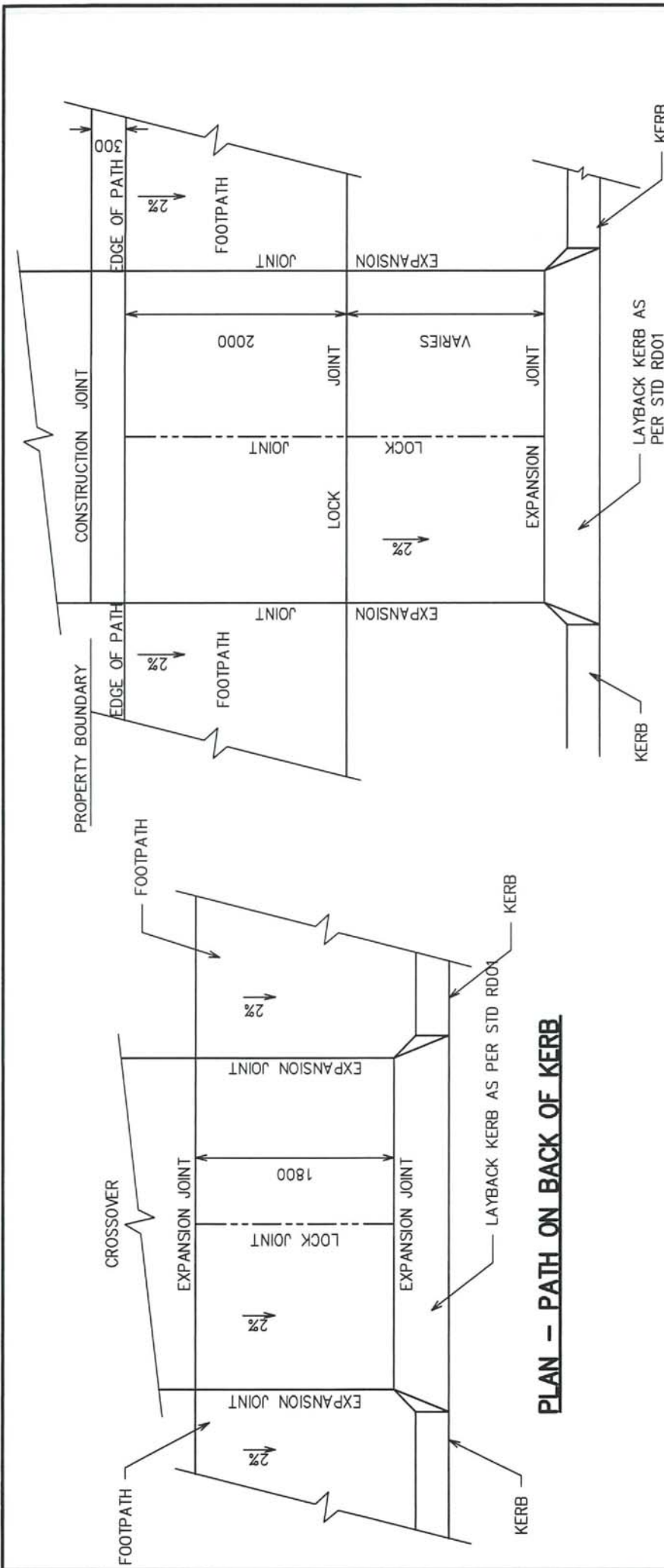

**PLAN - PATH AT PROPERTY BOUNDARY**

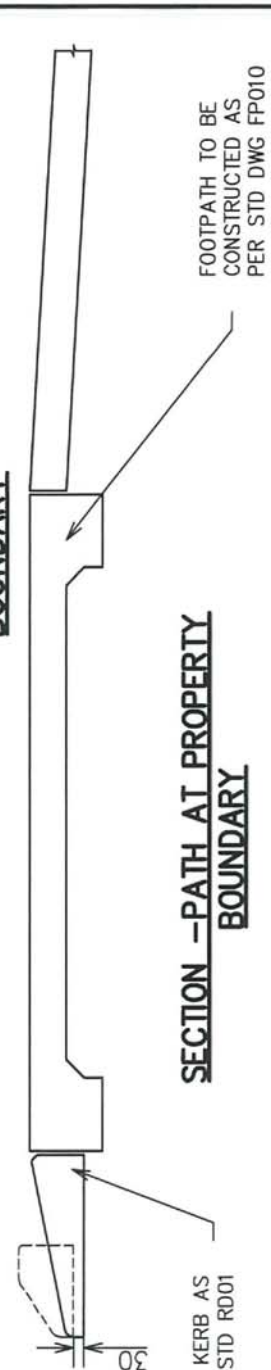

**SECTION - PATH AT PROPERTY BOUNDARY**

**NOTES:**

1. AS A MINIMUM LEVELS ARE TO BE THE SAME AT TOP OF KERB AND 2.0m BEHIND BACK OF KERB.
2. PATHS TO BE CONSTRUCTED IN ACCORDANCE WITH STD FP010.
3. KERBING TO BE CONSTRUCTED IN ACCORDANCE WITH STD RD01.
4. DIMENSIONS ARE IN MILLIMETRES.

REV No.	DATE	DESCRIPTION	BY	CHK'D	APPR	DATE	Designed	Approved
							Drawn	Position
							Draft Check	Date
							Eng. Check	
A	06/08	UPDATED FROM D06	BA					



TITLE: **CROSSOVERS AT SHARED PATHS**

FILE: \\STANDARD DRAWINGS\COM STANDARD DRAWINGS\CROSSOVERS\STD CR07.DWG  
 SCALE: AS SHOWN  
 DWG No: **A4 STD CR07/A**

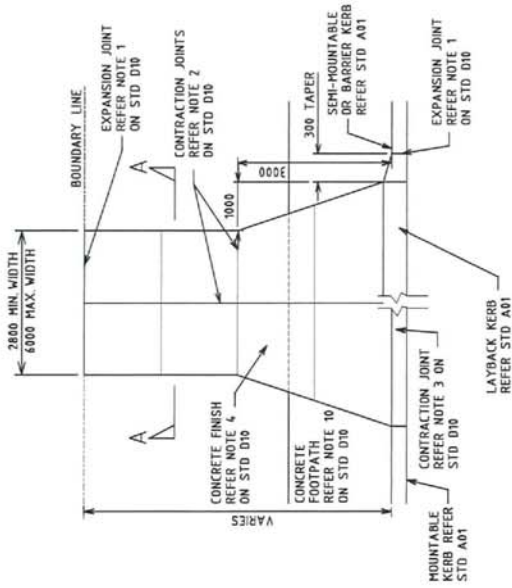

RESIDENTIAL CONCRETE CROSSOVER  
PLAN

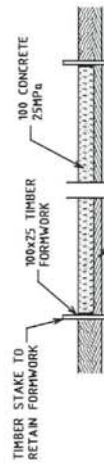

RESIDENTIAL CONCRETE CROSSOVER  
SECTION A-A

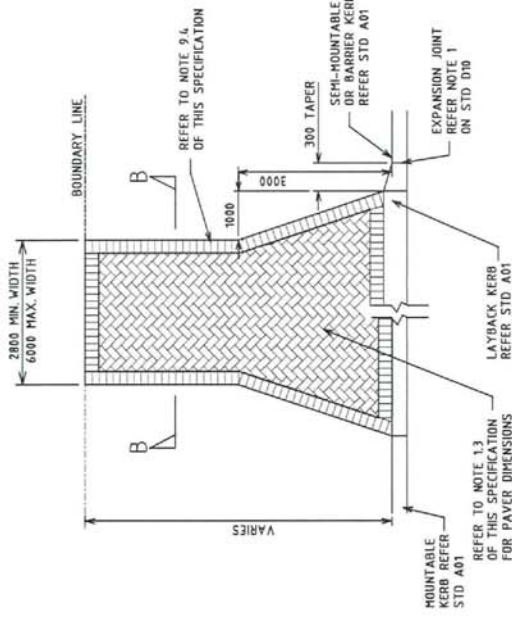

RESIDENTIAL BRICK PAVED CROSSOVER  
PLAN



RESIDENTIAL BRICK PAVED CROSSOVER  
SECTION B-B

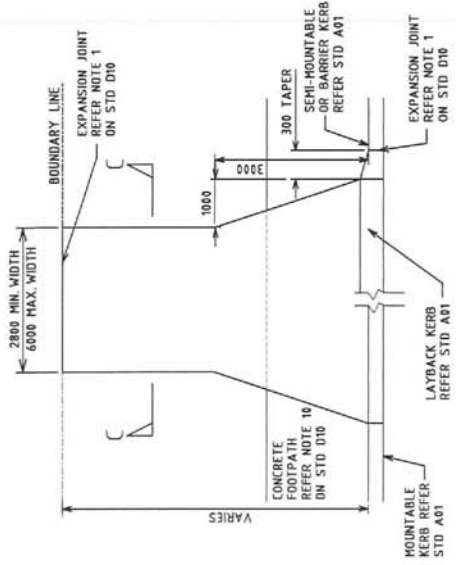

RESIDENTIAL BITUMEN CROSSOVER  
PLAN

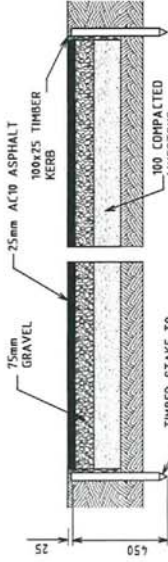

RESIDENTIAL BITUMEN CROSSOVER  
SECTION C-C

NOTE: WHERE FUTURE PATH CONSTRUCTION IS UNDERTAKEN BY THE CITY IT IS COUNCIL POLICY TO REMOVE ALTERNATIVE PAVING MATERIALS OTHER THAN PLAN GREY CONCRETE ACROSS THE CROSS-OVER AT THE WIDTH OF THE PATH, TO ENSURE UNIFORMITY OF THE PATH i.e. BRICKPAVING, ASPHALT & COLOURED CONCRETE FOR EXAMPLE WILL BE REMOVED.

No. DATE		REVISION		BY (UKD) APP'D DATE		CADD File Nos		NOT TO BE USED FOR CONSTRUCTION UNTIL SIGNED APPROVED		DESIGNER TO COMPLETE	
						MIRRESTATION UADONDETAILS STD. CONSTRUCTION STD D08 D08		APPROVED		DESIGNED	
						SURVEYED		POSITION		DRAWN	
						DATE		DATE		09/02	
						DATE		DATE		J.M.	
						DATE		DATE		J.M.	
1 09 02		CROSSOVER SPECIFICATIONS REVISED		J.M.						DRAFT CHECK	
										DESIGN ENG	
										SCALE	
										M.T.S.	
										JOB No.	
										A3	
										DWG No.	
										STD D08/1	

STANDARD DETAILS  
RESIDENTIAL CROSSOVERS

**NOTES:**

1. JOINTING DETAIL AS PER STD FP03.
2. WHERE MOUNTABLE KERB EXISTS A 12mm EXPANSION JOINT IS TO BE PROVIDED BETWEEN THE BACK OF KERB AND THE CROSSOVER.
3. CONCRETE CROSSOVER TO HAVE A BROOM FINISH WITH JOINTS AND EDGES HIGHLIGHTED. KERB TO HAVE SMOOTH FINISH.
4. DIMENSIONS ARE IN METRES.
5. SHOULD ANY TREE, POWER POLE, STREETLIGHT POLE, SIGN, PIT, MANHOLE OR ANY OTHER OBSTRUCTION BE LOCATED ON THE PROPOSED ALIGNMENT OF THE CROSSING THE APPLICANT SHALL BE LIABLE FOR THE COSTS ASSOCIATED WITH THE REMOVAL OR ALTERATION OF SAME.
6. TRENCH GRATING SHALL BE CONSTRUCTED BY THE APPLICANT IF CONSIDERED NECESSARY TO CUT OFF WATER ENTERING THE PROPERTY, OR ENTERING THE ROAD FROM INTERNAL DRIVEWAYS.
7. VEHICLE CROSSINGS ABUTTING OLD COAST ROAD AND PINJARRA ROAD EAST OF MANDURAH ROAD SHALL BE SUBJECT TO APPROVAL OF M.R.W.A.
8. WHERE THE EXISTING CONCRETE FOOTPATH/DUAL USE PATH IS ONLY 75mm THICK IT MUST BE REMOVED FROM THE AREA TO BE REPLACED BY THE CROSSOVER AND REINSTATED AT 150mm THICK CONCRETE.
9. AN EXPANSION JOINT IS TO BE PLACED AT EACH INTERFACE BETWEEN THE FOOTPATH AND CROSSOVER
10. KERBING DETAILS AS PER STD RD01 & STD RD02.

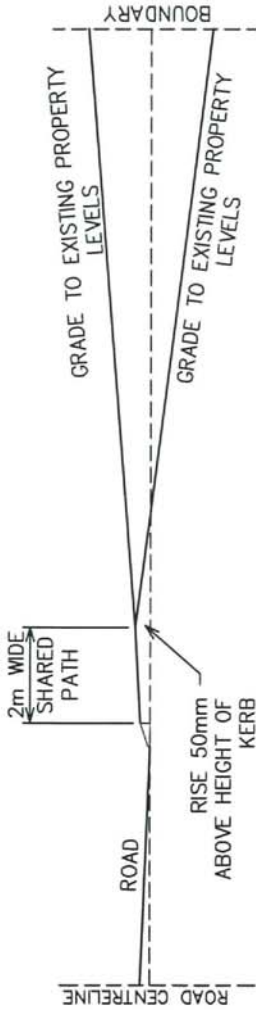

**CROSSOVER SPECIFICATIONS FOR MOUNTABLE KERBED LOADS**

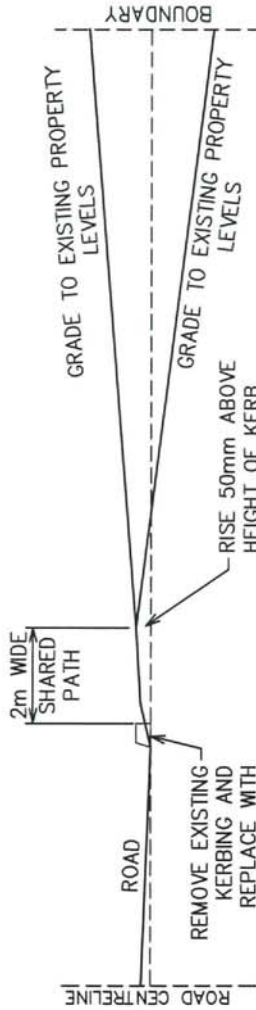

**CROSSOVER SPECIFICATIONS FOR BARRIER OR SEMI-MOUNTABLE KERBER LOADS.**

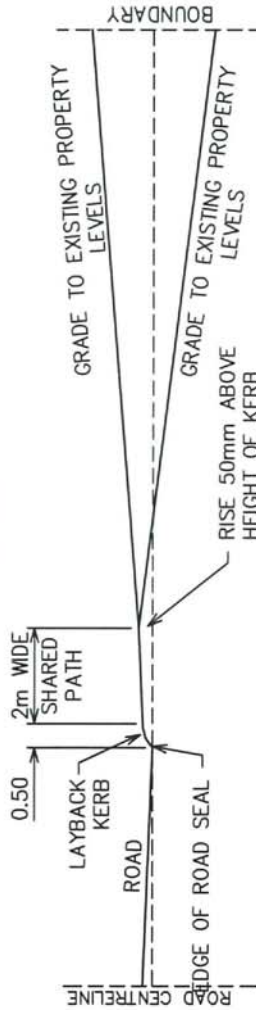

**CROSSOVER SPECIFICATIONS FOR UNKERBED ROADS**

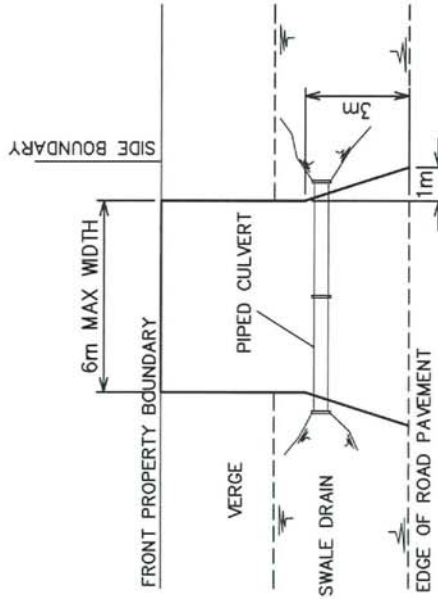

**RURAL CROSSOVER**

REV No.	DATE	DESCRIPTION	BY	CHK'D	APPR	DATE	Designed	Approved
							Drawn	Position
							Draft Check	Date
							Eng. Check	
A	04/08	UPDATED FROM D10	BA					



TITLE: **CROSSOVER SPECIFICATIONS**

FILE: \STANDARD DRAWINGS\0 - CROSSOVERS\STD CR10/A

SCALE: **N.T.S**

DWG No: **A4 STD CR10/A**